

Deka[®] **unigy II**[®]

SPACE SAVER[®] SYSTEMS **Interlock[™] 45, 75, 95 & 125 AH** **Non-Interlock[™] 45, 75 & 95 AH** *Installation and Operation Manual*



**California
Proposition 65
Warning:**

Batteries, battery posts, terminals and related accessories contain lead and lead compounds, and other chemicals known to the state of California to cause cancer and birth defects or other reproductive harm. **Wash hands after handling.**

TABLE OF CONTENTS

Safety Precautions

Protective Equipment3
 Procedures3

Receiving & Storage

Receiving Inspection.....3
 Unpacking3
 Storage3

Installation

General4
 Grounding4
 Electric Code for Maintenance Access4
 Floor Anchoring & Module Arrangements4
 Module Installations4

Electrical Connection

Connector Assembly4
 Terminal Assembly4
 Final Assembly Check Procedure5
 Parallel Strings5
 Module Front Shield Assembly5
 Top Protective Shield Assembly5
 Terminal Plate Shield Assembly5

System Operations

Charger Voltage6
 Operating Temperatures6
 Cell Voltage6
 Equalizing6

Record Keeping

Voltages, Temperatures
 & Ohmic Readings6

Maintenance

Annual Inspection7
 Rectifier Ripple Voltage.....7
 Battery Cleaning7
 Capacity Testing7

Cell Removal Procedure7

FIGURES7-17

APPENDIX A

Recharge Interval Chart18

APPENDIX B

Voltage Compensation Chart.....19

APPENDIX C

Battery Maintenance Report20

APPENDIX D

UNIGY II SPACESAVER® System
 Acid Volumes & Weights21

DANGER Lead Acid Battery Contains: Lead, Sulfuric Acid (Electrolyte), Lead Compounds.

Harmful if swallowed, inhaled, or in contact with skin.
 Acid causes severe skin burns and eye damage.
 May damage fertility or the unborn child if ingested or inhaled.
 May cause harm to breast-fed children.
 May cause cancer if ingested or inhaled.
 Causes skin irritation, serious eye damage.
 Contact with internal components may cause irritation or severe burns.
 Causes damage to central nervous system, blood and kidneys through prolonged or repeated exposure if ingested or inhaled.
 Irritating to eyes, respiratory system, and skin.
 May form explosive air/gas mixture during charging.
 Extremely flammable gas (hydrogen). Explosive, fire, blast or projection hazard.
 Obtain special instructions before use.
 Do not handle until all safety precautions have been read and understood.
 Wash thoroughly after handling.
 Do not eat drink or smoke when using this product.
 Avoid contact during pregnancy/while nursing.

Wear protective gloves/protective clothing, eye protection/face protection.
 Use only outdoors or in a well-ventilated area.
 Avoid contact with internal acid.
 Do not breathe dust/fume/gas/mist/vapors/spray.
 Keep away from heat/sparks/open flames/hot surfaces. No smoking.
 IF SWALLOWED OR CONSUMED: rinse mouth. Do NOT induce vomiting.
 Call a poison center/doctor if you feel unwell.
 IF ON CLOTHING OR SKIN (or hair): Remove/Take off immediately all contaminated clothing and wash it before reuse. Rinse skin with water/shower.
 IF INHALED: Remove person to fresh air and keep comfortable for breathing. Immediately call a POISON CENTER or doctor/physician.
 IF IN EYES: Rinse cautiously with water for several minutes. Remove contact lenses, if present and easy to do. Continue rinsing.
 If exposed/concerned, or if you feel unwell seek medical attention/advise.
 Store locked up, in a well-ventilated area, in accordance with local and national regulation.
 Dispose of contents/container in accordance with local and national regulation.
 Keep out of reach of children.

PROPOSITION 65 WARNING: battery posts, terminals and related accessories contain lead and lead compounds, chemicals known to the State of California to cause cancer and reproductive harm. Batteries also contain other chemicals known to the State of California to cause cancer. WASH HANDS AFTER HANDLING.

WARNING: Risk of fire, explosion or burns. Do not disassemble or incinerate. Not recommended for inverted use. Follow product charging instructions. High Voltage: Risk of shock. Do not touch uninsulated terminals or connectors.

Do Not Remove Vent Valve

**Manufactured by: East Penn Manufacturing Co.
 102 Deka Road, Lyon Station, PA 19536 USA 610-682-6361**

4-1034

15

UL Recognized Component
 MH17218

Pb

Pb

BATTERIES AND RELATED PARTS CONTAIN LEAD

WASH HANDS AFTER HANDLING!

CALIFORNIA PROPOSITION 65 WARNING:
 Batteries, battery posts, terminals and related accessories contain lead and lead compounds, and other chemicals known to the state of California to cause cancer and birth defects or other reproductive harm.

California Proposition 65 Workplace Warning Sign
 Must be posted in workplace near batteries. 7/04

SAFETY PRECAUTIONS

VRLA (Valve Regulated Lead-Acid) batteries have the electrolyte immobilized within the cell; however, electrical hazard associated with batteries still exists. **Work performed on these batteries should be done with the tools and the protective equipment listed below.** VRLA battery installations should be supervised by personnel familiar with batteries and battery safety precautions.

WARNING: Risk of fire, explosion or burns. Do not disassemble, heat above 40°C, or incinerate.

Protective Equipment

Although VRLA batteries can vent or leak small amounts of electrolyte, electrical safety is the principle but not the only concern for safe handling. Per IEEE 1188 recommendations, the following minimum set of equipment for safe handling of the battery and protection of personnel shall be available:

1. Safety glasses with side shields, or goggles, or face shields as appropriate. (Consult application specific requirements)
2. Electrically insulated gloves, appropriate for the installation.
3. Protective aprons and safety shoes.
4. Portable or stationary water facilities in the battery vicinity for rinsing eyes and skin in case of contact with acid electrolyte.
5. Class C fire extinguisher.
6. Acid neutralizing agent.
7. Adequately insulated tools.
8. Lifting devices of adequate capacity, when required.

Procedures

The following safety procedures should be followed during installation: **(Always wear safety glasses or face shield when working on or near batteries. Refer to Figure 1)**

1. These batteries are sealed and contain no free electrolyte. Under normal operating conditions, they do not present any sulfuric acid danger. However, if the battery jar or cover is damaged, sulfuric acid could be present. **Sulfuric acid is harmful to the skin and eyes. Flush affected area with water immediately and consult a physician if splashed in the eyes. Consult SDS for additional precautions and first aid measures. SDS sheets can be obtained at www.eastpenmanufacturing.com.**
2. **Prohibit smoking and open flames, and avoid arcing in the immediate vicinity of the battery.**
3. Do not wear metallic objects, such as jewelry, key chains, while working on batteries. Do not store un-insulated tools in pockets or tool belt while working in vicinity of battery.
4. Keep the top of the battery dry and clear of tools and other foreign objects.
5. Provide adequate ventilation (**per IEEE standard 1187 and/or Federal, State & Local codes**) and follow recommended charging voltages.
6. **Never** remove or tamper with the pressure relief valves, unless for cell removal. Warranty void if vent valve is removed.
7. Inspect all flooring and lifting equipment for functional adequacy.
8. Adequately secure battery modules, racks, or cabinets to the floor.
9. Connect support structures to ground system in accordance with applicable codes.
10. The below IEEE Standards contain additional information. Other standards may be relevant to your specific application.

IEEE 1187 – Recommended Practice for Installation Design of VRLA Batteries

IEEE 1188 – Recommended Practice for Maintenance, Testing, of VRLA Batteries

IEEE 1189 – Selection of VRLA Batteries for Stationary Applications

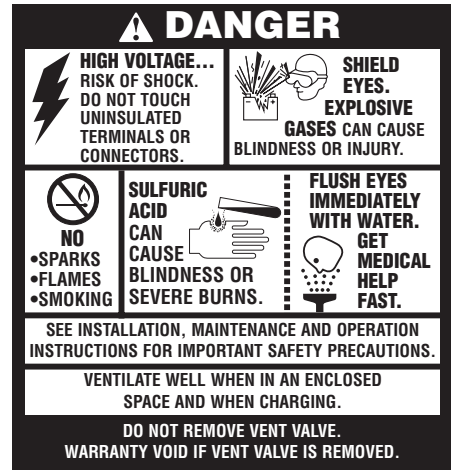

California Proposition 65 Warning:

Batteries, battery posts, terminals and related accessories contain lead and lead compounds, and other chemicals known to the state of California to cause cancer and birth defects or other reproductive harm. **Wash hands after handling.**

Fig. 1-1

RECEIVING & STORAGE

Receiving Inspection

Upon receipt, and at the time of actual unloading, each package should be visually inspected for any possible damage or electrolyte leakage. If either is evident, a more detailed inspection of the entire shipment should be conducted and noted on the bill of lading. Record receipt date, inspection data and notify carrier of any damage.

Unpacking

1. **Always wear eye protection.**
2. Check all batteries for visible defects such as cracked containers, loose terminal posts, or other unrepairable problems. Batteries with these defects must be replaced.
3. Check the contents of the packages against the packaging list. Report any missing parts or shipping damage to your East Penn agent or East Penn Mfg. Co. immediately.
4. Never lift batteries by the terminal posts.
5. When lifting batteries, the proper equipment is needed such as a forklift or a portable crane. Always check the lifting capacities of the equipment being used and never lift more than one module and or cell at a time.

Storage

1. Cells should be stored indoors in a clean, level, dry, cool location. Recommended storage temperature is 0°F to 90°F (-18°C to 32°C).
2. Stored lead-acid batteries self discharge and must be given a boost charge to prevent permanent performance degradation. **0°F to 77°F (-18°C to 25°C) storage:** Batteries should be recharged six months from date of manufacture. **>77°F (25°C) storage:** Use the chart in Appendix A for recharge intervals. Voltage readings should be taken on a monthly basis. Cells that reach 2.10 volts per cell should be recharged regardless of scheduled interval. Record dates and conditions for all charges during storage.
3. If a boost charge is required: the recommended charge is 24 hours at a constant voltage equal to 2.40 volts per cell.
4. Do not store beyond 12 months.
5. Store in horizontal position only.

INSTALLATION

General

Caution should be taken when installing batteries to insure no damage occurs. The battery cabinet, tray, rack, etc. shall be inspected for sharp edges that could cause damage to the battery casing. Batteries shall not be dropped, slid, or placed on rough or uneven surfaces such as tray lips or grated flooring. Mishandling of batteries could result in equipment damage or human injury. East Penn will not be liable for damage or injury as a result of mishandling or misuse of the product.

Grounding

When grounding the battery system, proper techniques should be applied per electrical standards, such as NEC and/or local codes, as well as user manual of specific applications.

Two .201 diameter x .750 center holes are provided in back of each module to accept a #6 x .750 center compression grounding lug. The holes must be tapped for a 1/4-20UNC thread and paint must be removed for a proper grounding pad location.

Electric Code for Maintenance Access

Refer to ANSI/NFPA-70 National Electric Code for access and working space requirements around the battery. A minimum of 36" aisle space is recommended in front of the battery for service and inspection.*

**Note: Battery system and/or individual module grounding, if required, is the installer's responsibility.*

Floor Anchoring & Module Arrangements

See East Penn Mfg. Co.'s schematic diagram illustration. One is supplied with each shipment. If it cannot be located, contact East Penn Mfg. Co. for a copy. Refer to your delivery number, located on the packing slip. This will aid in obtaining the proper drawing.

Module Installations

Assemble modules per the following details.

CAUTION: Never lift more than one module at a time with the lifting slings. (See Fig. 3-2, pg. 9.)

1. UBC Zone 4 hardware included for Interlock™ module assembly (45, 75 & 95 AH). (See Fig. 3-4, pg. 10)
2. Unbolt the floor-mounting channel from the top of the battery.
3. Use the two slings provided to lift modules.
Note: For Interlock™ module lift the top module slightly and slide front. (This will release the interlock tabs and will free itself from the remaining stack.) (See Fig. 3-2, pg. 9)
4. For the Non-Interlock modules, reference figure 3.5, pg. 11 for marking hole locations to mount base supports to floor. For the Interlock modules, use 1-piece base for marking floor hole location. **(See local building codes for anchor bolt requirements, anchor bolts not included.)**
5. Remove the next module in the same manner as the first. Place in position. Note: For Interlock™ module slide back allowing the tabs to lock in place. (No rear bolts required) (See Fig. 3-2, pg. 9)
6. Each battery is shipped with its own schematic. Make sure the polarity on the batteries match the drawings.

ELECTRICAL CONNECTION

Connector Assembly

1. The contact surfaces of each individual post on every cell have been cleaned and coated with a thin film of no-ox-ID "A" grease at the factory. Assure the contact surfaces are free of dust or dirt prior to assembly.

Connector Assembly (con't)

2. The Interlock™ and Non-Interlock™ battery (45, 75 & 95 AH) are supplied with connector package "1CU" requiring one connector per post. Install the connectors loosely to allow for final alignment, then torque to 125 ± 5 inch pounds (14.1 ± .5 Nm.) **The installation and direction of the post bolts is important!** (Refer to Fig. 4-1, 4-2 and 4-3 pg. 11 and 12; Fig. 4-4, pg. 4. For proper direction when inserting into posts.) The 125 AH battery is supplied with a 2CU connector package as standard. (Refer to Fig.5-1A, pg. 13 for special connector orientation for side terminal & stack to stack connections.)
3. Batteries used in high rate discharge applications require multiple connectors per connection. (Refer to optional connector packages in Fig. 4-5, pg. 4)



Fig. 4-4

Connector Packages	
Standard Package (45, 75 & 95 AH)	
1CU: (1) 1/8" connector / post	
≤ 250 amps / 480 wpc (5-15 plate)	
≤ 450 amps / 720 wpc (17-27 plate)	
≤ 550 amps / 880 wpc (29-33 plate)	
Optional Packages	
2CU: (2) 1/8" connectors / post (Standard on 125 AH)	
≤ 1000 amps / 1600 wpc (9-33 plate)	
4CU: (4) 1/8" connectors / post	
≤ 2000 amps / 3200 wpc (13-33 plate)	
6CU: (6) 1/8" connectors / post	
≤ 3000 amps / 4800 wpc (25-33 plate)	
Corresponding Bolt Package	
1CU: 1/4-20 x 1 1/4" long — JMP1428	
2CU: 1/4-20 x 1 1/2" long — JMP1407	
4CU: 1/4-20 x 1 3/4" long — JMP1435	
6CU: 1/4-20 x 2" long — JMP1409	

Fig. 4-5

Terminal Assembly

1. Attach the terminal mounting bracket to the module frame. (See Fig. 5-1, pg. 13 for Interlock™ and Fig. 5-2 and 5-2A for Non-Interlock™, pg. 14 for Side Terminal; See Fig. 5-3 and Fig. 5-3A, pg. 15 for Top Terminal)
2. Attach the terminal plates or the terminal connectors to the battery posts and then torque to 125 ± 5 inch-pounds (14.1 ± .5 Nm). (See Fig. 5-3 and Fig. 5-3A, pg. 15 for 95 AH vs. 125 AH)
3. For cable connection assembly, (See Fig. 7-1, pg. 16 and Fig. 7-1A, pg. 17.)

Final Assembly Check Procedure

1. For future identification of all cells, number individual cells in sequence, beginning with number one (1) at the positive end of the battery. The last cell of the battery is located at the negative output terminal.
2. Read and record the voltages of the individual cells to assure that they are connected properly. The total battery voltage should be approximately equal to the number of cells connected in series multiplied by the measured voltage of one cell. If the measurement is less, recheck the connections for proper polarity. Verify that all cell and battery connections have been properly torqued.
3. Measure and record the intercell connection resistance using a micro-ohms meter. This helps determine the adequacy of initial connection installation and can be used as a reference for future maintenance requirements. Refer to the recording forms in Appendix C of this manual. Review the records of each connection and detail resistance measurements. Clean, remake, and remeasure any connection that has a resistance measurement greater than **10%** of the average of all the same type connections (i.e. intercell, intermodule, etc.).
4. Battery performance is based on the output at the battery terminals. Therefore, the shortest electrical connection between the battery system and the operating equipment results in maximum total system performance.

Select cable size based on current carrying capability and voltage drop.

Cable size should not provide a greater voltage drop between the battery system and operating equipment than specified. Excessive voltage drop in cables will reduce the desired reserve time and power from the battery system.

Parallel Strings

When paralleling valve-regulated batteries, the capacity, arrangement, and external circuit length should be identical for each battery. Wide variation in the battery circuit resistance can result in unbalanced charging (i.e., excessive charging currents in some batteries and undercharging in others). As a result, cell failures in one battery string and subsequent loss of performance capabilities of that string will result in higher loads in the other parallel string(s), which may exceed the ratings of the battery connections. This can damage the battery system and dramatically shorten battery life.

Module Front Shield Assembly

1. Attach one black clip to each end of the clear shield. (See Fig. 5-4, pg. 16 and 5-5, pg. 5.)
2. Install the fully assembled shield into the tabs on the module. (See Fig. 5-6, pg. 5 & Fig. 5-4, pg. 16)

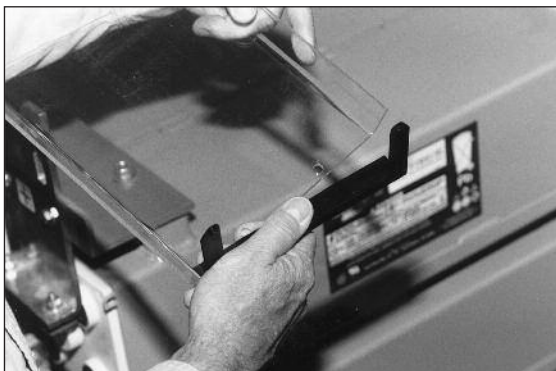

Fig. 5-5

Top Protective Shield Assembly

For side terminal assembly, attach the black top protective cover to the highest front shield.

For top terminal assembly, cut the black protective cover to fit between the terminals and then attach to the front shield. (See Fig. 5-4, pg. 16.)

Terminal Plate Shield Assembly

For side terminal shield assembly, (Refer to Fig. 5-1, pg 13 for Interlock™ and Fig. 5-2 and 5-2A for Non-Interlock™, pg. 14 and Fig. 5-7, pg. 5)

For top terminal shield assembly, (Refer to Fig. 5-3, pg. 15 and Fig. 5-8, pg. 5)



Fig. 5-6

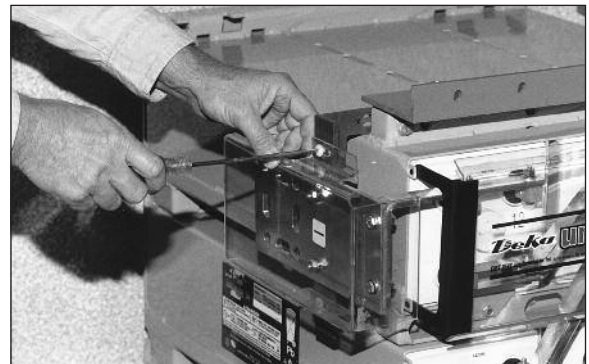

Fig. 5-7

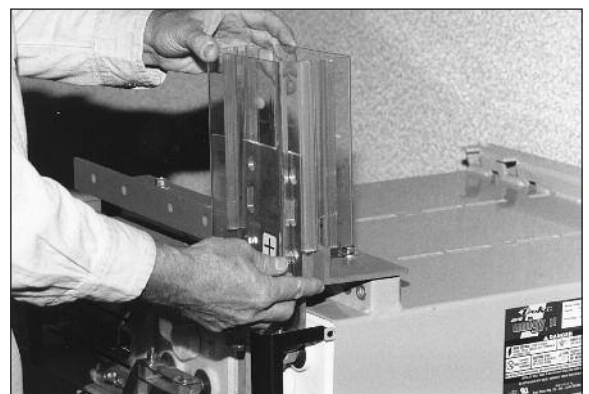

Fig. 5-8

SYSTEM OPERATIONS

Charger Voltage

These batteries are designed for continuous float applications.

Float / Standby

2.25 vpc \pm 0.01 @ 77°F (25°C)

When setting the float voltage on the charger, the system should be set to float at the nominal cell float voltage times the number of cells per string. The charger must be able to maintain the system voltage within \pm 0.5% of the desired level at all times. The desired float voltage varies with temperature according to the table in the next column.

Temperature Compensation

Battery voltage should be adjusted for ambient temperature variations.

2mV per °C (1.8°F) per cell

Consult **Voltage Compensation Chart** in Appendix B for temperature compensation voltage maximum and minimum limits

Battery Operation

Battery operating temperature will affect battery capacity and operating life.

Operation at temperatures greater than 77°F (25°C) will reduce the operating life of the battery. For every 13°F (7°C) increase in operating temperature above 77°F (25°C), the warranty period will be proportionally reduced by 50% as shown below:

Operating Temp.	Proportional % of Life
77°F (25°C)	100%
81°F (27°C)	80%
87°F (30°C)	60%
90°F (32°C)	50%

The average cell operating temperature should not exceed 95°F (35°C) and should never exceed 105°F (40.5°C) for more than an eight-hour period. **If operating temperatures are expected to be in excess of 95°F (35°C), contact East Penn for recommendations.**

Discharging at temperatures less than 77°F (25°C) will reduce the capacity of the battery.

Cells must not be operated below 50°F (10°C). **If operating temperatures are expected to be less than 50°F (10°C), contact East Penn for recommendations.**

Batteries must be located in a manner that the individual cells do not vary by more than 5°F (2.8°C) between the lowest and highest individual cell temperatures.

Cell Voltage

Although the charger must maintain the system voltage within \pm 0.5%, individual battery [cell] voltages may vary by \pm 0.05 volts per cell of the average cell float voltage.

Equalizing

Upon installation of the battery system, an optional charge of 14.40V per battery \pm 0.06 @ 77°F (25°C) [2.40 vpc \pm 0.01 @ 77°F (25°C)] for 24 hours (not to exceed 24 hours) can be applied. (Note: Verify that the higher battery voltage will not adversely affect any other connected equipment). **If this is done, be sure to reset the charging equipment to the proper float voltage.**

RECORD KEEPING

Voltages, Temperatures & Ohmic Readings

Record keeping is an important part of stationary battery maintenance and warranty coverage. This information will help in establishing a life history of the battery and inform the user if and when corrective action needs to be taken. (Refer to Appendix C, Battery Maintenance Report)

Voltages, Temperatures & Ohmic Readings (con't)

While it is acceptable to operate at temperatures less than 77°F (25°C), it will require longer charging time to become fully recharged. Also, the capacity will be less at operating temperatures below 77°F (25°C).

After installation and when the batteries have been on float charge for one week, the following data should be recorded:

1. Battery terminal voltage
2. Charger voltage
3. Individual cell float voltages
4. Individual cell ohmic readings. On a 4-post cell place meter leads on the left positive - left negative posts or right positive - right negative posts. For 6-post cells, measure from center positive - center negative posts. Do not measure diagonally from positive to negative posts. (See Fig. 6-1, pg. 6.)
5. Ambient temperatures
6. Terminal connections should be checked to verify that the installer did torque all connections properly (125 \pm 5 in.-lbs.). Micro-ohm readings should be taken across every connection. (Refer to Fig. 6-2, pg. 6) Refer to meter manufacturer's instructions for proper placement of probes. If any reading differs by more than **20%** from its initial installation value, re-torque the connection to 125 \pm 5 inch-pounds. If the reading still remains high, clean contact surfaces according to Step 2 under Connector Assembly.



Fig. 6-1



Fig. 6-2

MAINTENANCE

Always wear eye protection when working on or near batteries. Keep sparks and open flames away from batteries at all times. See Safety Precautions on pg. 3.

Annual Inspection ⁽¹⁾

1. Conduct a visual inspection of each cell.
2. Record the battery string voltage.
3. Record the charger voltage.
4. Record the individual cell voltages. The accuracy of the DMM (Digital Multimeter) must be .05% (on dc scale) or better. The DMM must be calibrated to NIST traceable standards. Because float readings are affected by discharges and recharges, these readings must be taken when batteries have been on continuous, uninterrupted float for at least one month. Cells should be within ± 0.05 volts of the average cell float voltage.
5. Record the ambient temperatures.
6. Record individual cell ohmic readings.
7. Record all interunit and terminal connection resistances. Micro-ohm readings should be taken during this inspection. If any reading differs by more than 20% from initial readings taken, retorque the connection. Recheck the micro-ohm reading. If the reading remains high, clean the contact surface according to installation portion of this manual.

⁽¹⁾ **Other Maintenance Inspection intervals follow IEEE 1188**

Rectifier Ripple Voltage

FREQUENCY

Ripple that has a frequency greater than 667Hz (duration less than 1.5ms) is acceptable, unless it is causing additional battery heating.

Ripple that has a frequency less than 667Hz (duration greater than 1.5ms), must meet the following voltage specification to be acceptable.

VOLTAGE

Ripple voltage shall be less than 0.5% peak to peak of the manufacturer's recommended string voltage.

Failure to comply can void the warranty.

Battery Cleaning

Batteries, cabinets, racks, and modules should be cleaned with clear water, a mixture of baking soda and water or East Penn Mfg supplied battery cleaner (part # 00321).

Never use solvents to clean the battery.

Capacity Testing

Per IEEE 1188 "Capacity testing is used to trend battery aging. The result of a capacity test is a calculation of the capacity of the battery. The calculated capacity is also used to determine if the battery requires replacement."

Do not discharge the battery beyond the specified final voltage. When discharging at higher rates, extra connectors may need to be added to prevent excessive voltage drop and / or excessive temperature rise. When performing capacity testing and recording data use IEEE 1188 instructions. Should it be determined that any individual battery (ies) [cell(s)] need to be replaced, contact East Penn.

CELL REMOVAL PROCEDURE

1. Before removing cells, review Safety Precautions on pg. 3 of this manual. Contact East Penn Manufacturing Company, Inc. with specific questions or concerns.
2. Refer to Fig. 8-1 through 8-4 below for specific instructions.

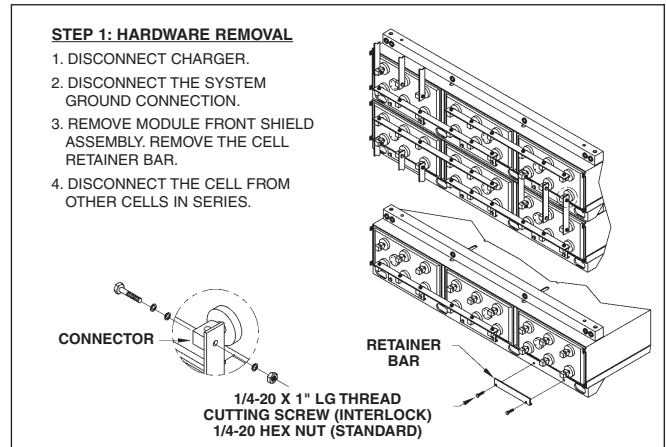

Fig. 8-1

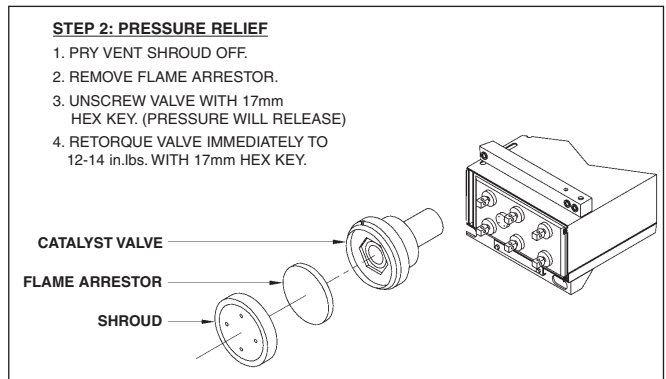

Fig. 8-2

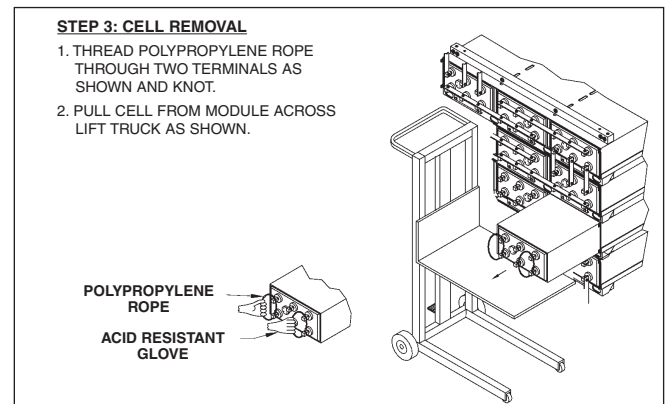

Fig. 8-3

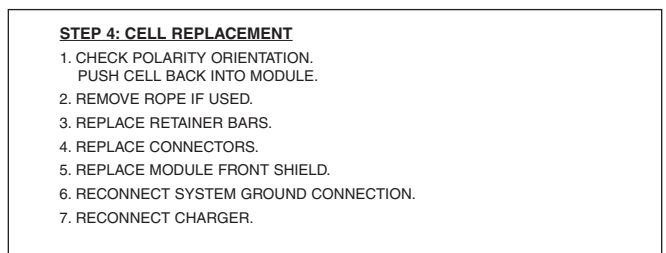

Fig. 8-4

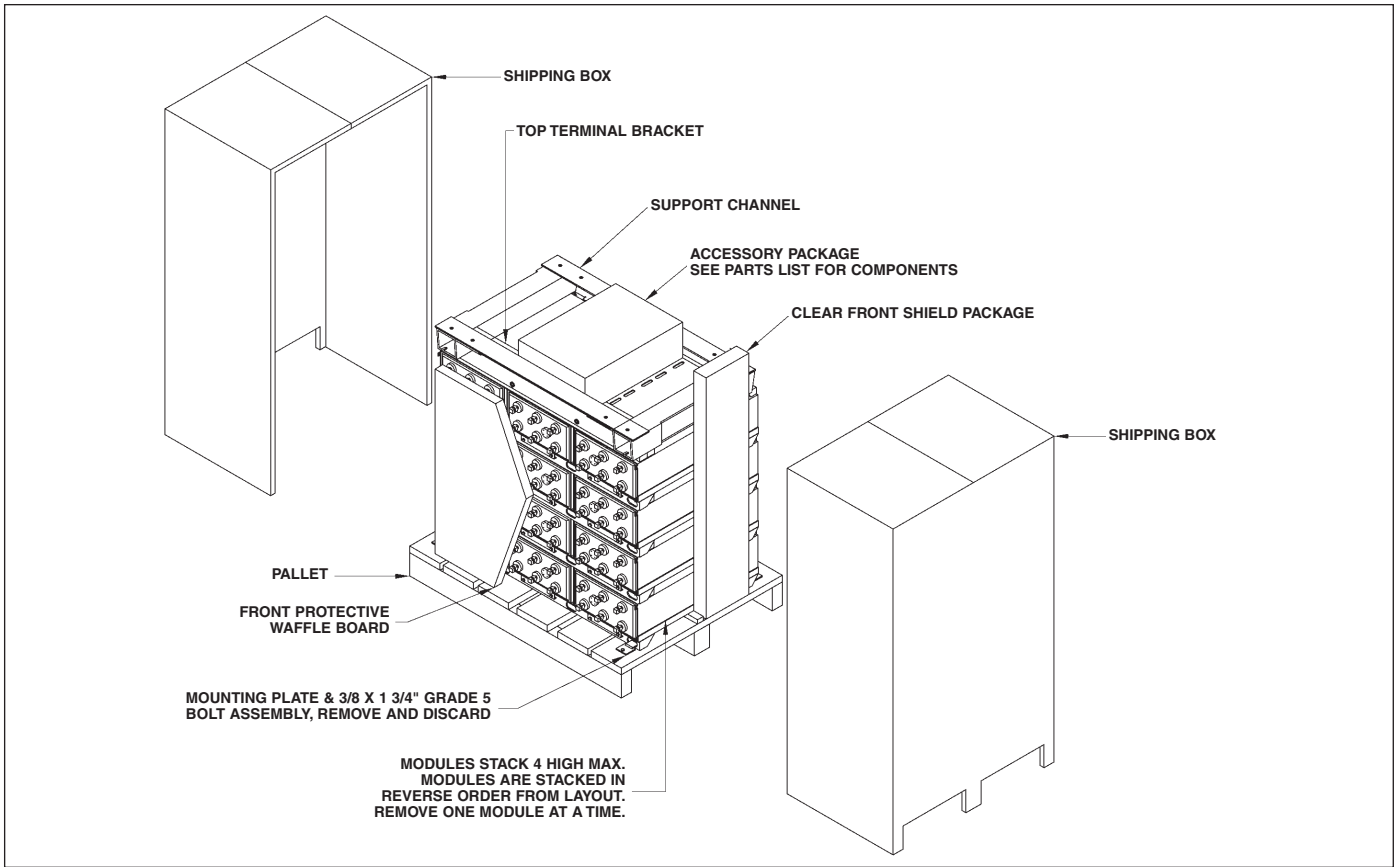

Fig. 2-1

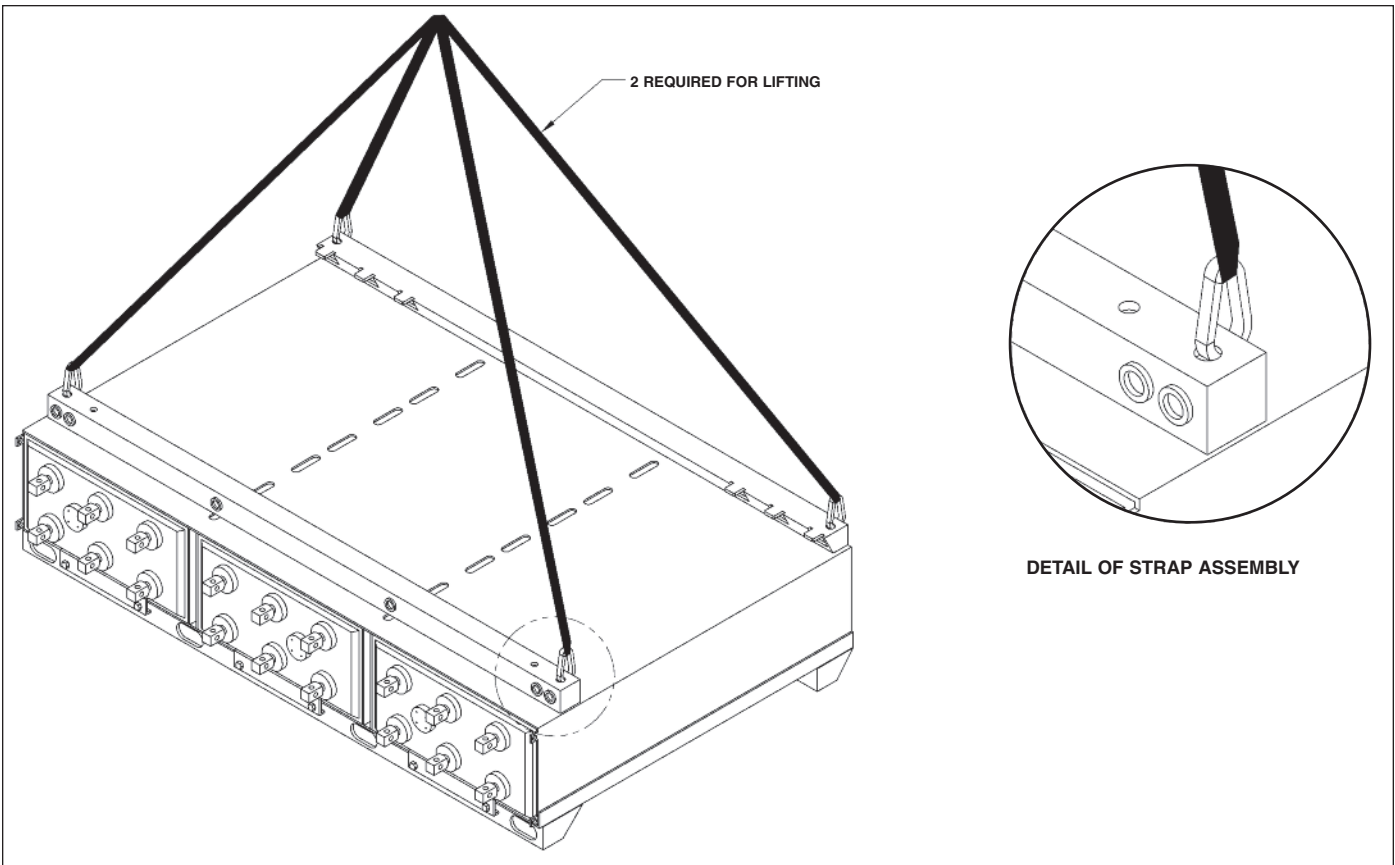

Fig. 3-1

Interlock™ System Leveling

When leveling Unigy II Interlock™ battery systems that are installed with a 1-piece base support, it is critical to note that the back channel is 3/16" shorter than the front channel.

If a level is placed across the front and rear channels, a 3/16" shim should be placed on top of the rear channel in order to level properly.

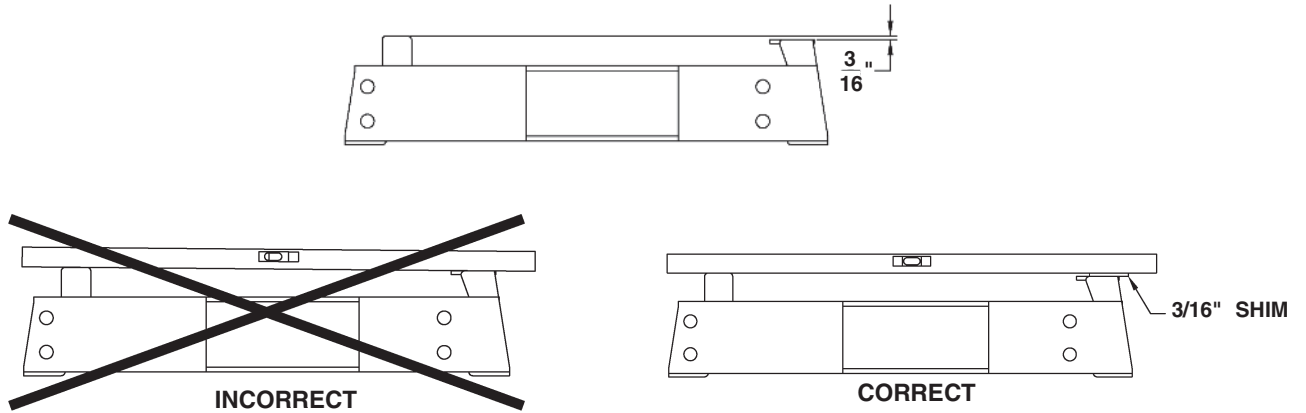

Fig. 3-1A

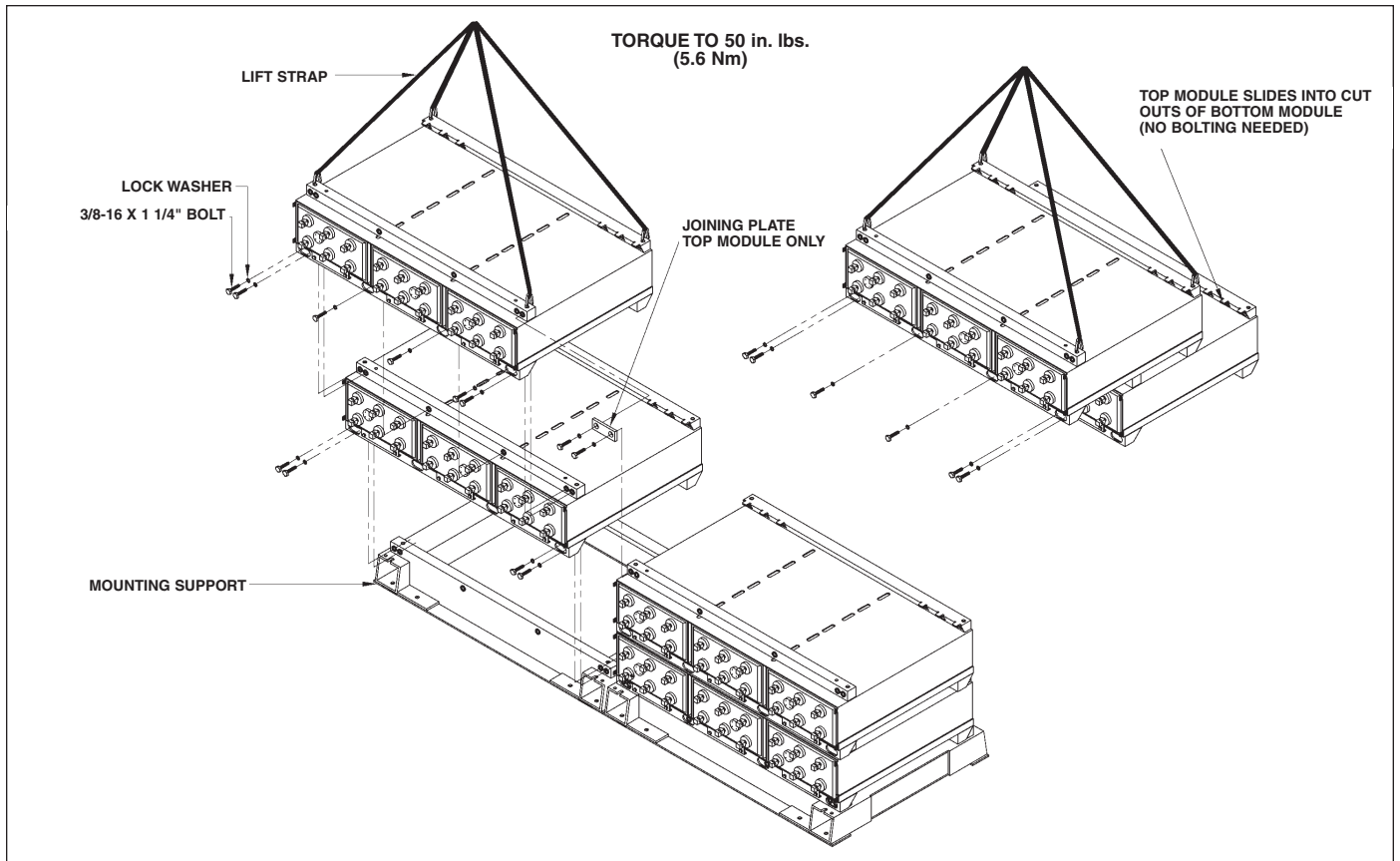

Fig. 3-2

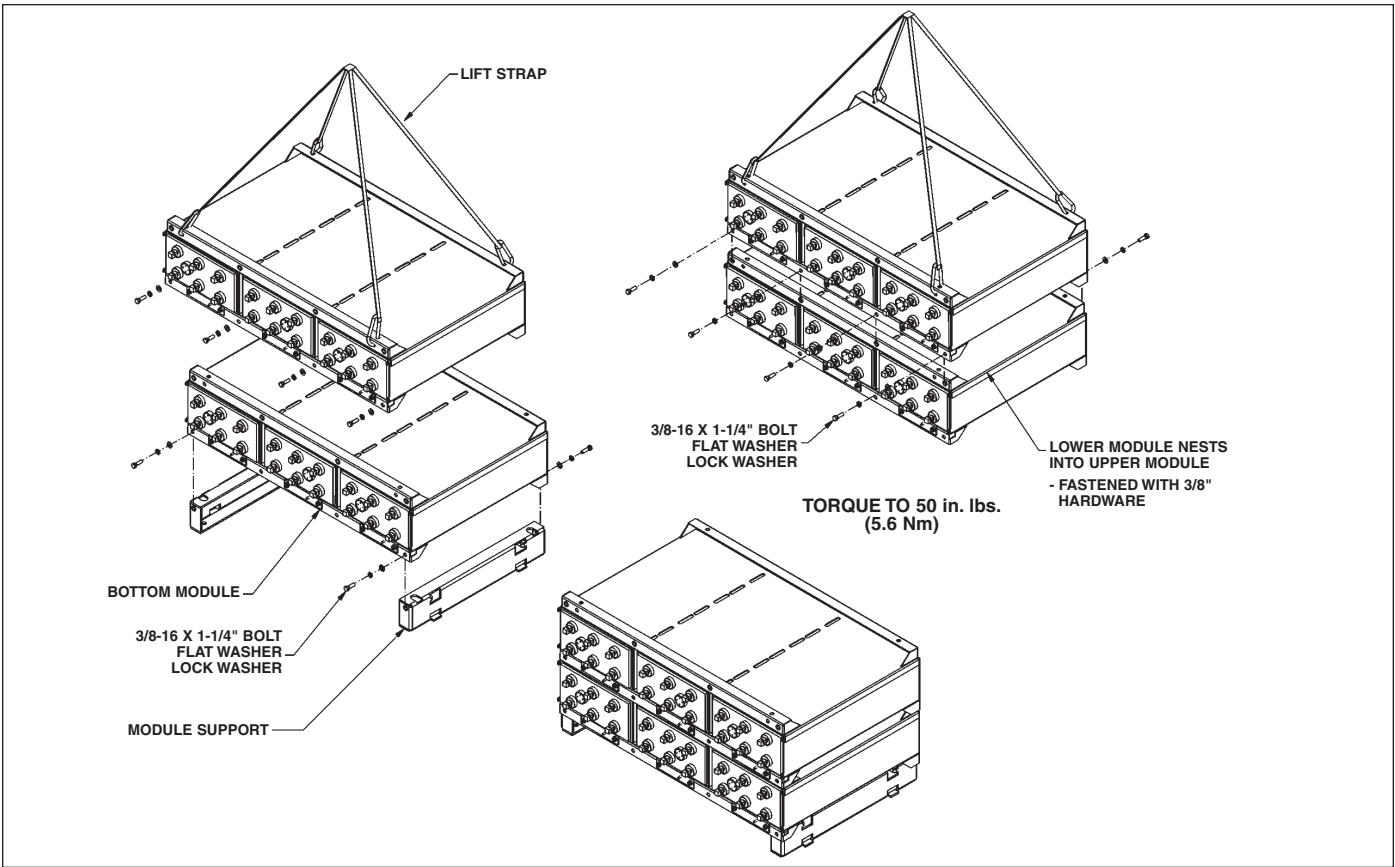

Fig. 3-3

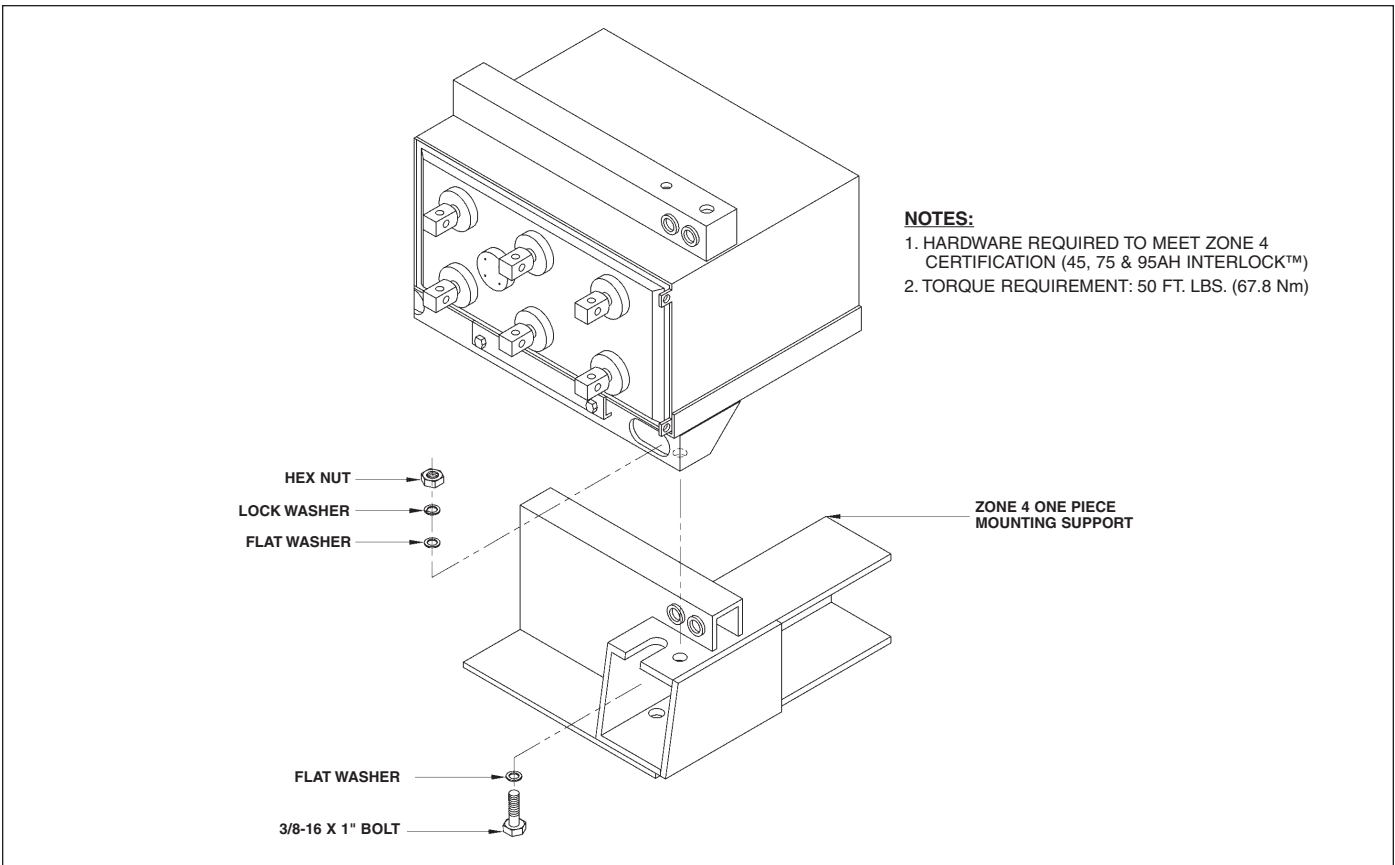

Fig. 3-4

NO. OF PLATES	3 & 6 CELL MODULES						2 & 4 CELL MODULES		NO. OF PLATES	3 & 6 CELL MODULES						2 & 4 CELL MODULES	
	45 A.H.		75 A.H.		95 A.H.		95 A.H.			45 A.H.		75 A.H.		95 A.H.		95 A.H.	
	X	Y	X	Y	X	Y	X	Y		X	Y	X	Y	X	Y	X	Y
5	11.72	10.64	11.72	17.74	—	—	—	—	21	—	10.64	23.57	17.74	23.57	20.34	14.80	20.34
7	16.16	10.64	16.16	17.74	16.16	20.34	9.86	20.34	23	—	10.64	25.82	17.74	25.82	20.34	16.30	20.34
9	20.66	10.64	20.66	17.74	20.66	20.34	12.86	20.34	25	—	10.64	28.07	17.74	28.07	20.34	17.80	20.34
11	25.16	10.64	25.16	17.74	25.16	20.34	15.86	20.34	27	—	10.64	30.32	17.74	30.32	20.34	19.30	20.34
13	29.66	10.64	29.66	17.74	29.66	20.34	18.86	20.34	29	—	10.64	32.57	17.74	32.57	20.34	20.80	20.34
15	34.17	10.64	34.17	17.74	34.17	20.34	21.86	20.34	31	—	10.64	34.82	17.74	34.82	20.34	22.30	20.34
17	—	10.64	19.07	17.74	19.07	20.34	11.80	20.34	33	—	10.64	37.07	17.74	37.07	20.34	23.80	20.34
19	—	10.64	21.32	17.74	21.32	20.34	13.30	20.34									

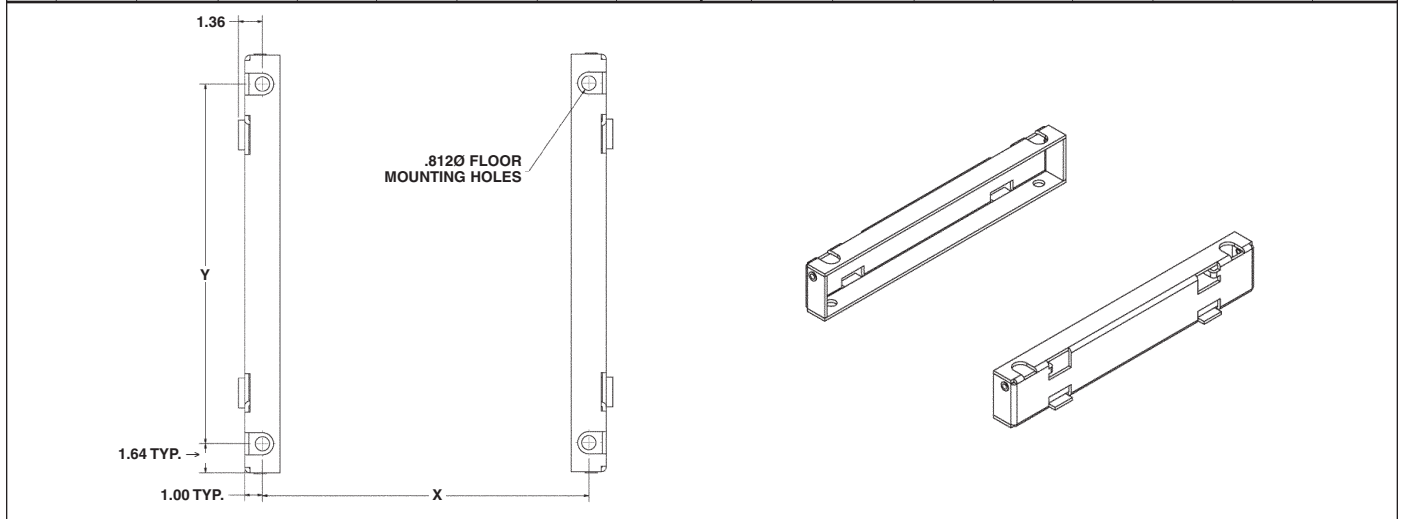

Fig. 3-5

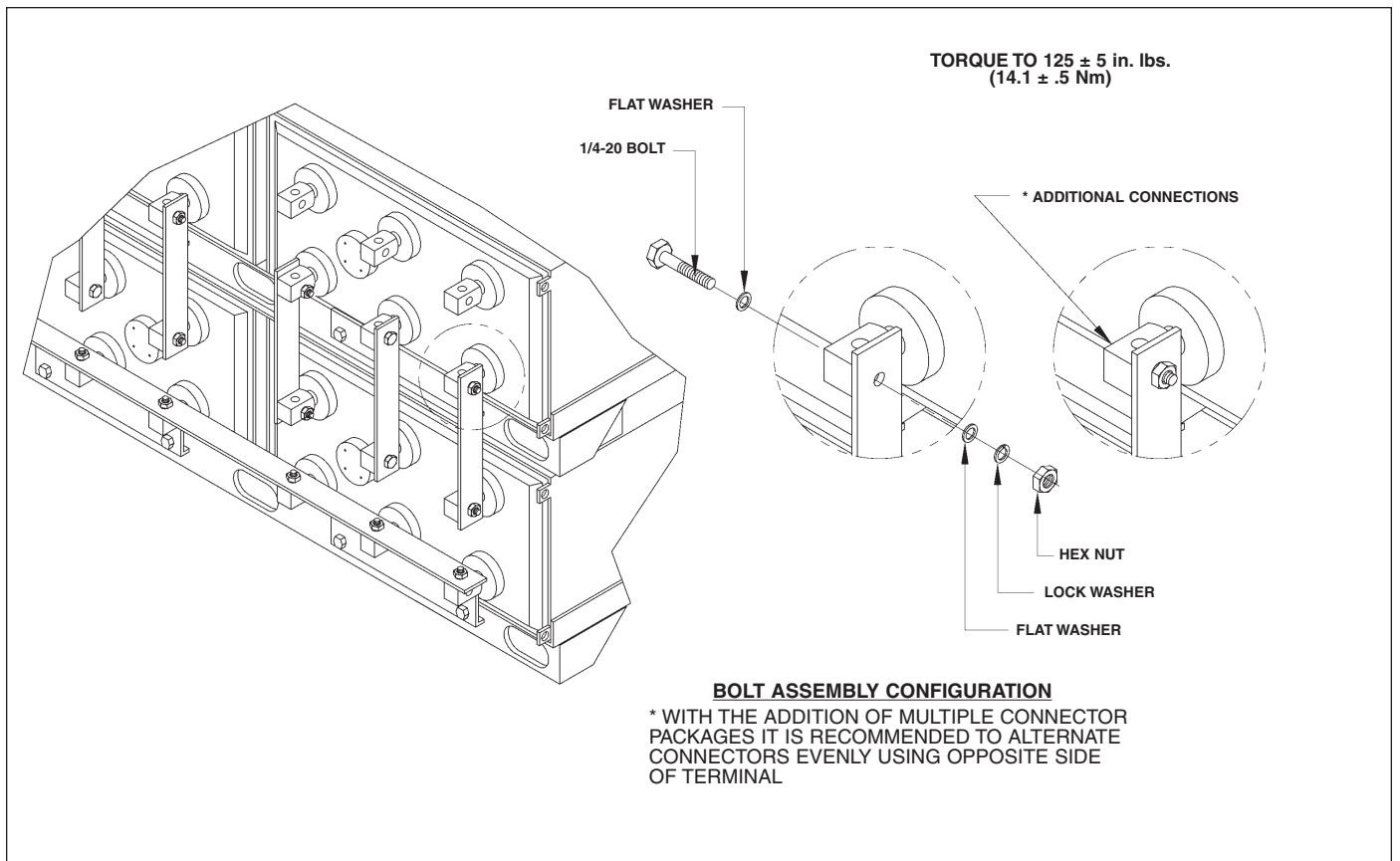

Fig. 4-1

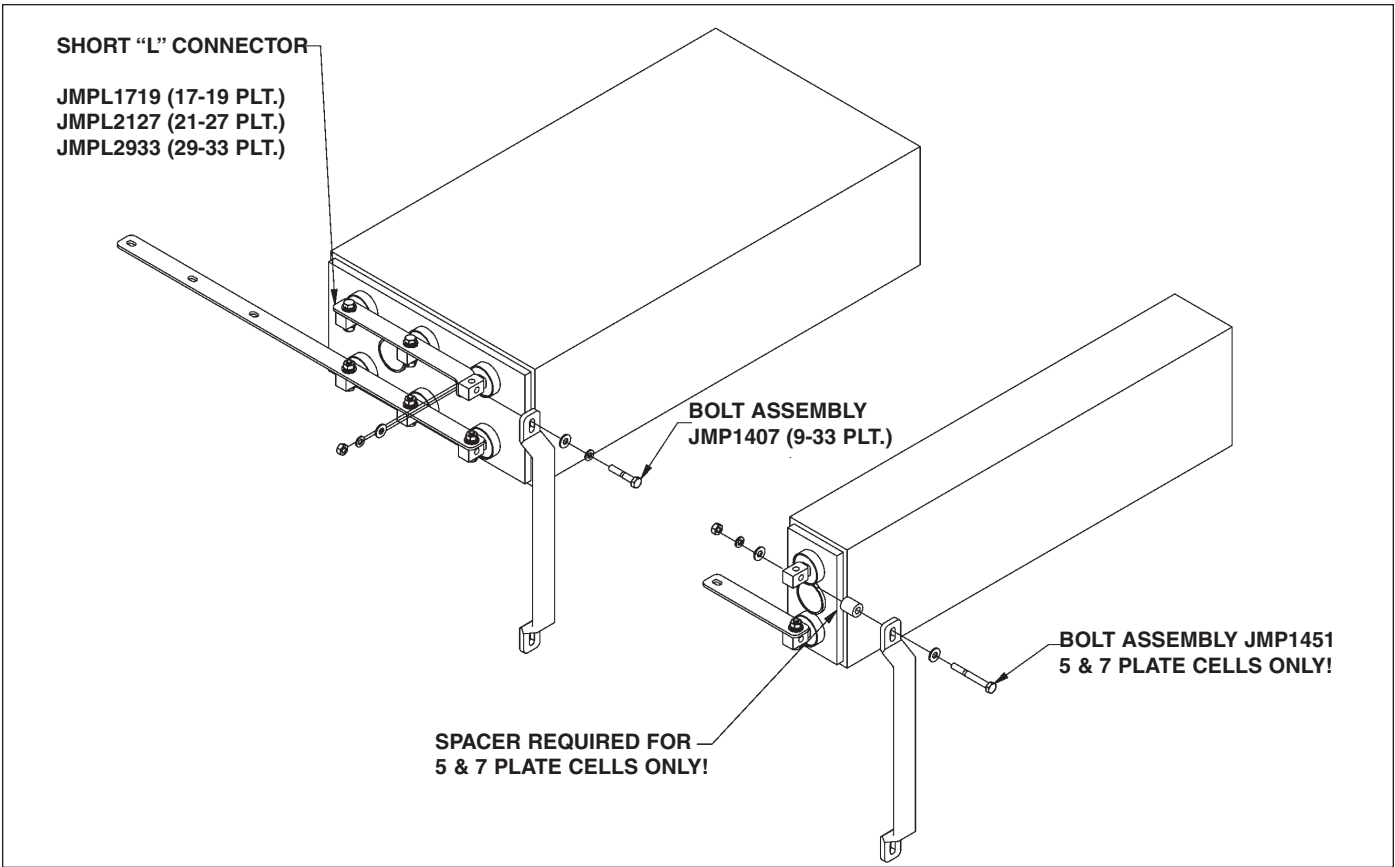

Fig. 4-2

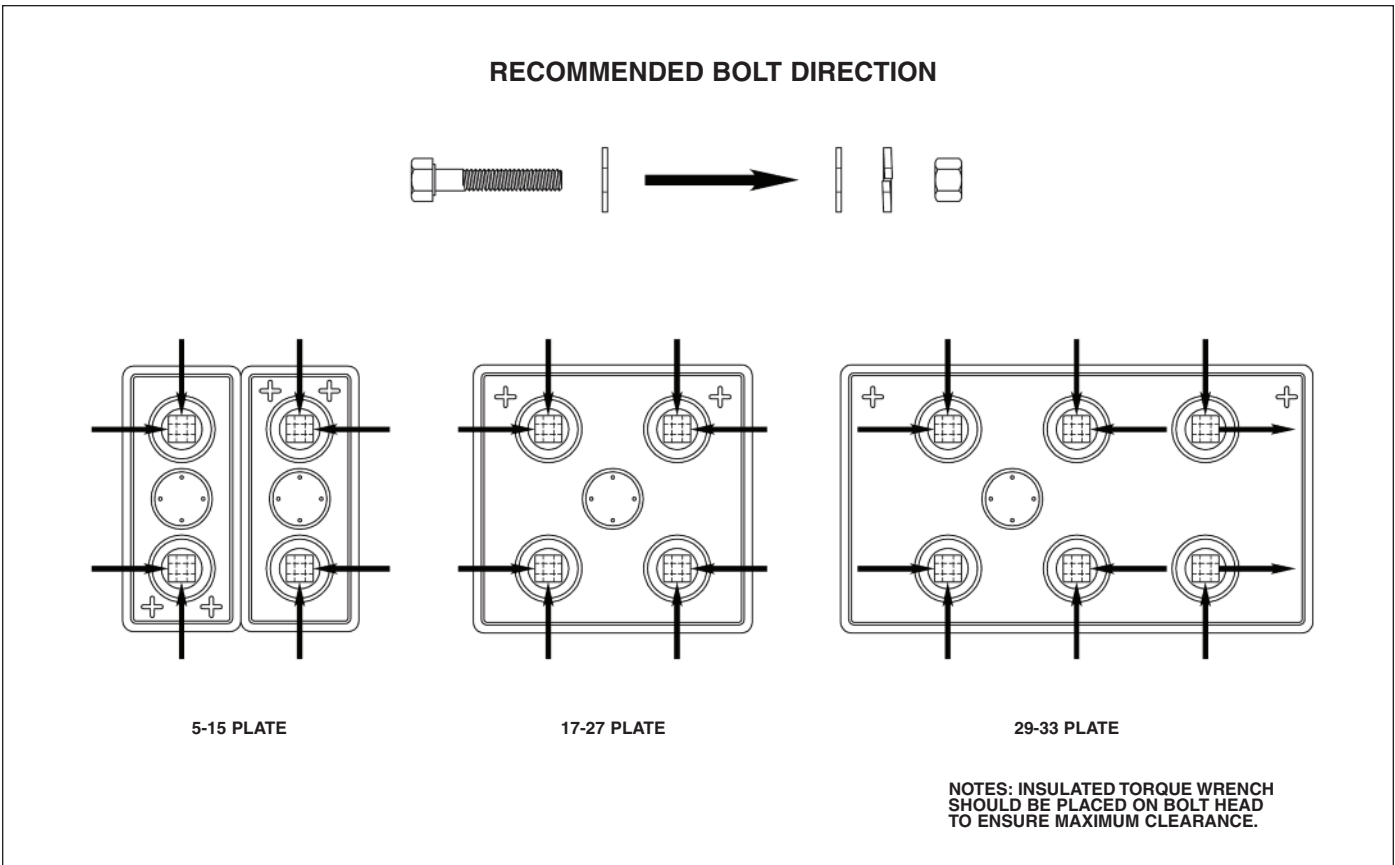

Fig. 4-3

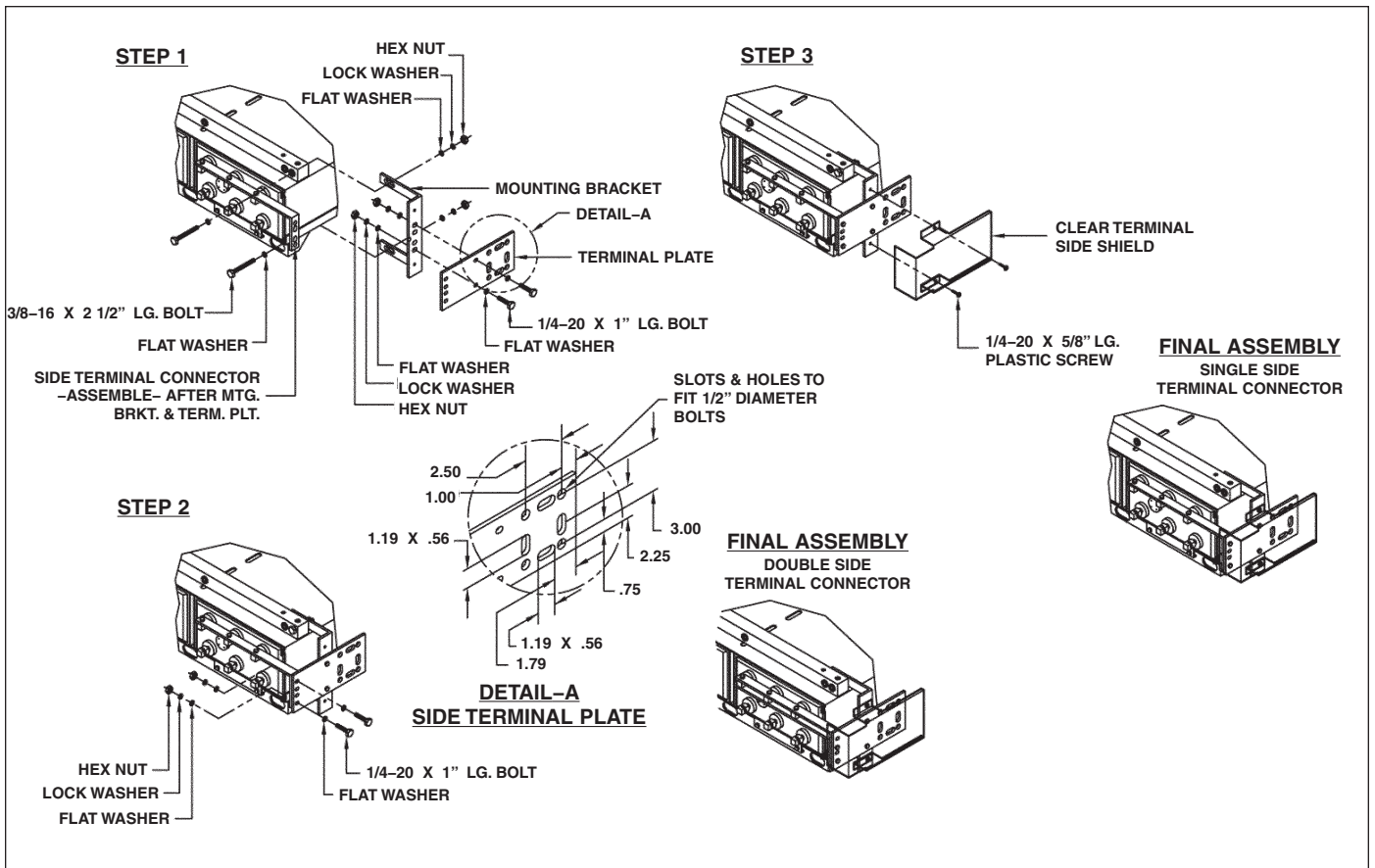

Fig. 5-1

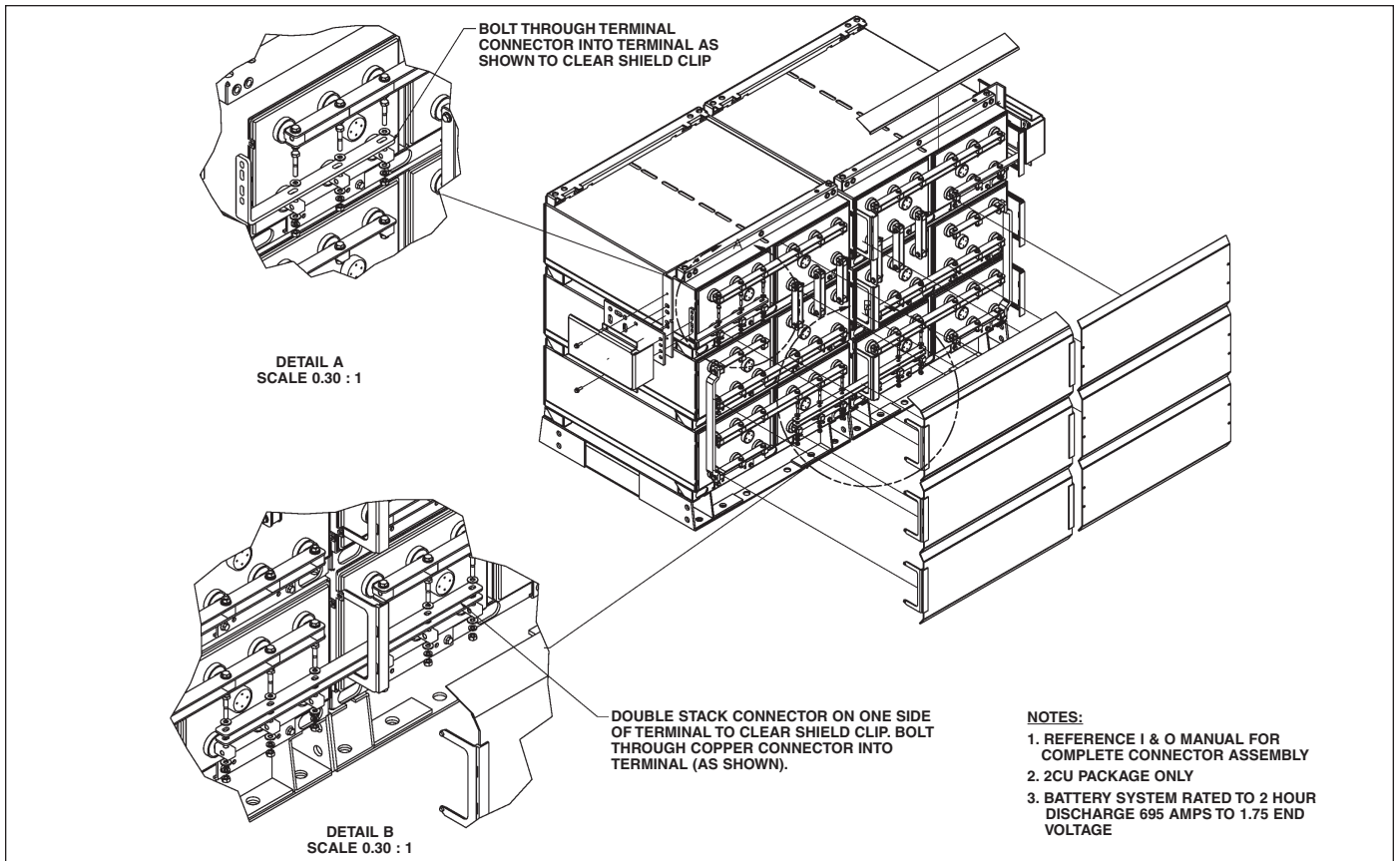

Fig. 5-1A

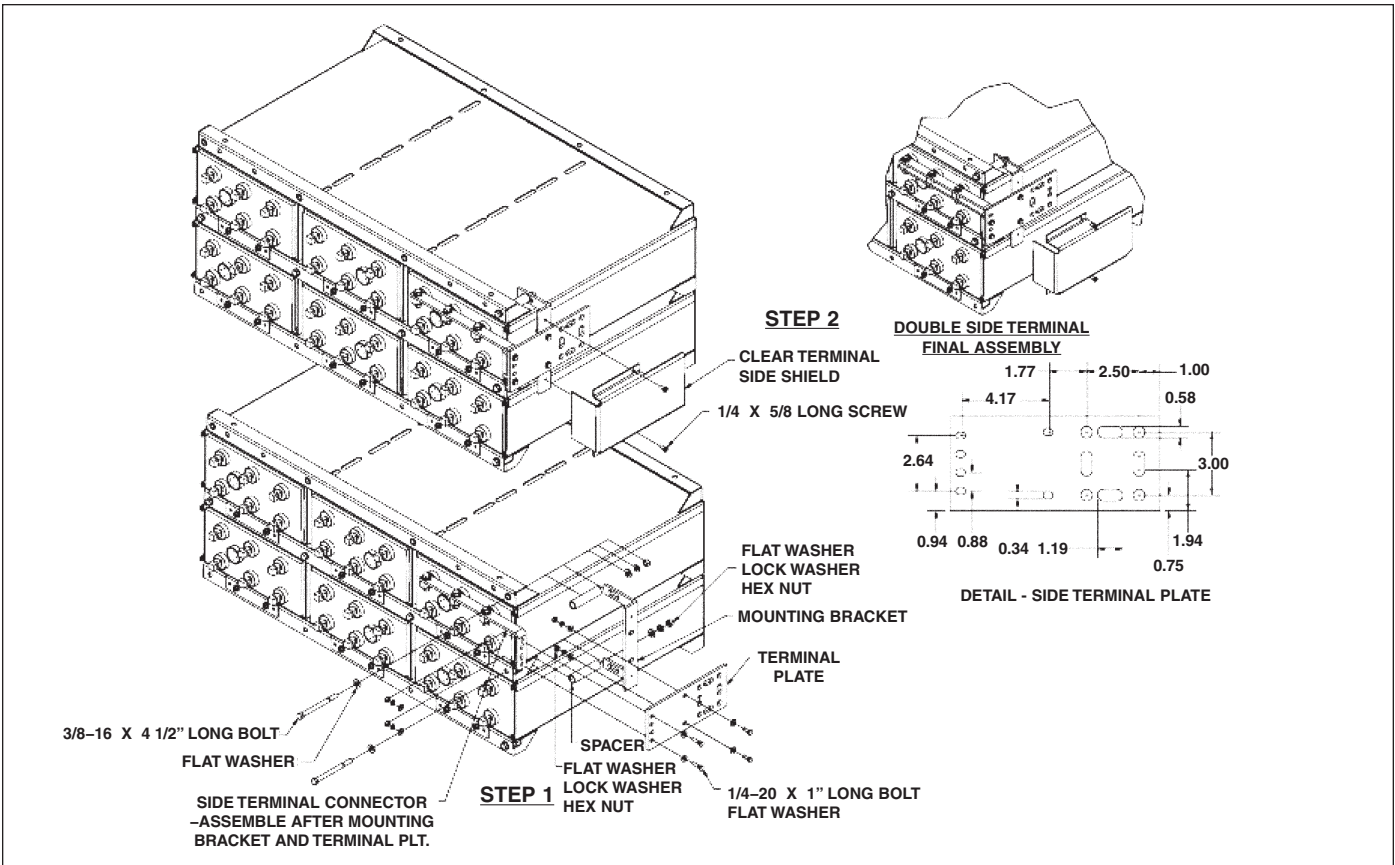

Fig. 5-2

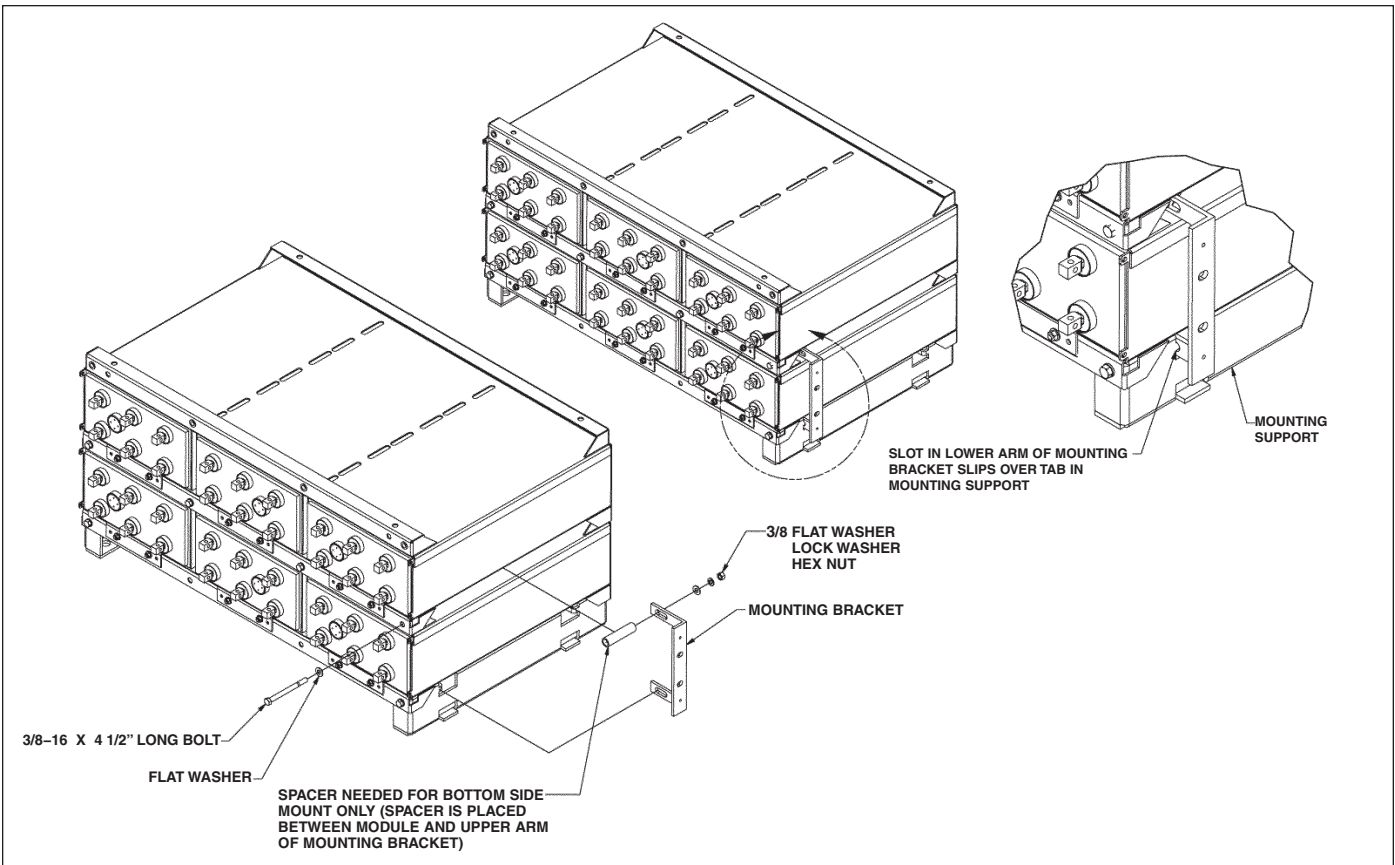

Fig. 5-2A

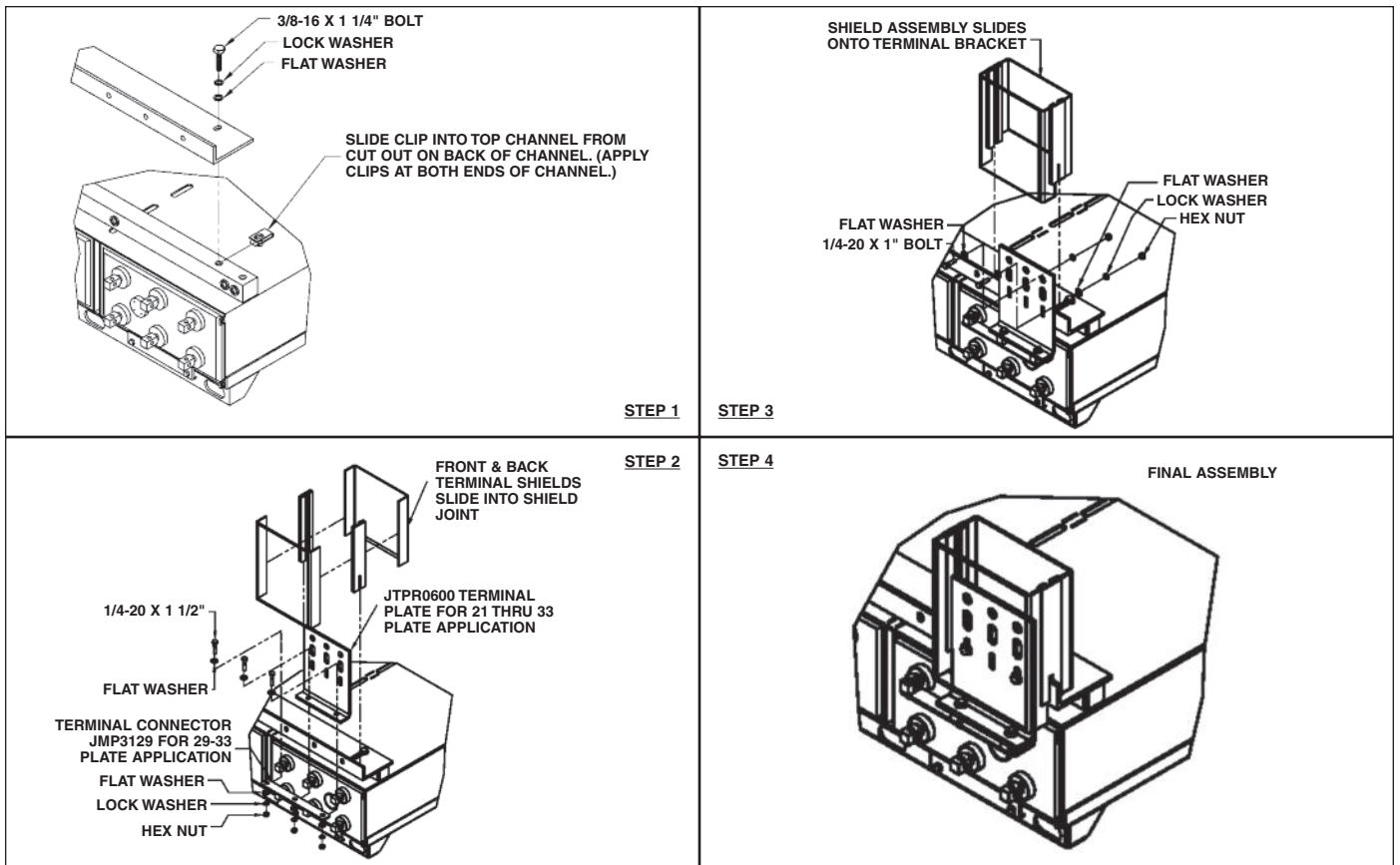

Fig. 5-3 (45, 75 & 95 AH)

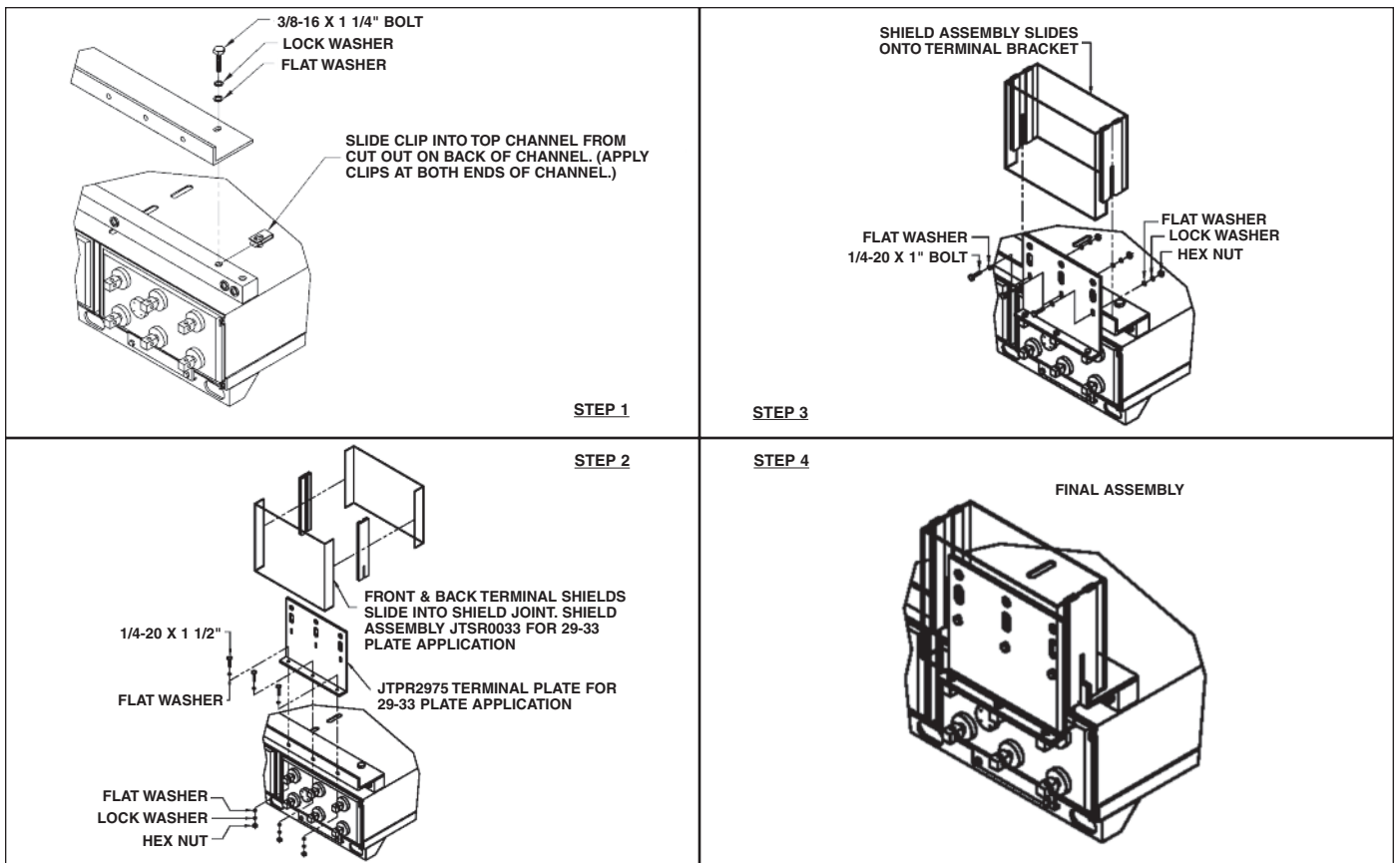

Fig. 5-3A (125 AH)

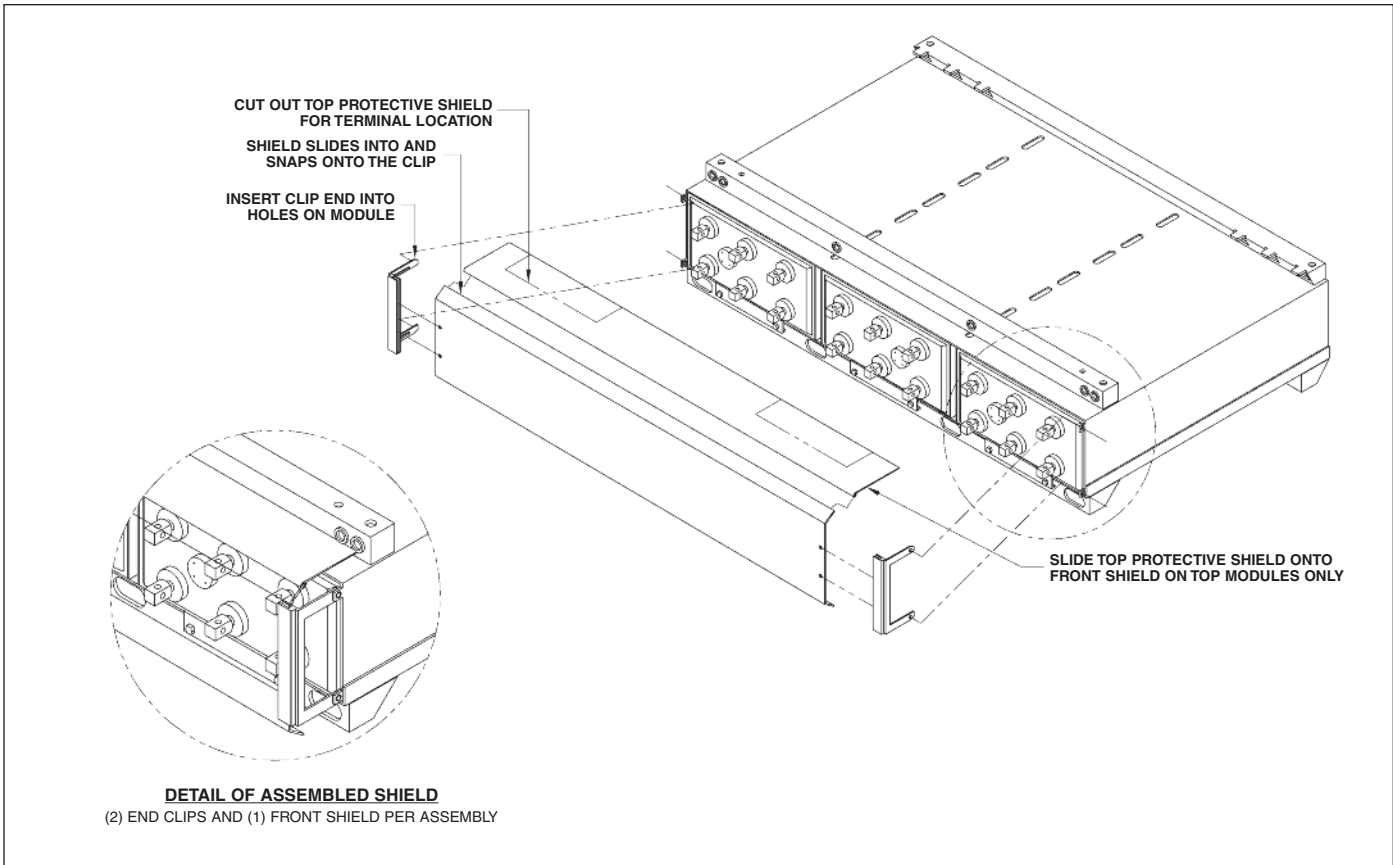

Fig. 5-4

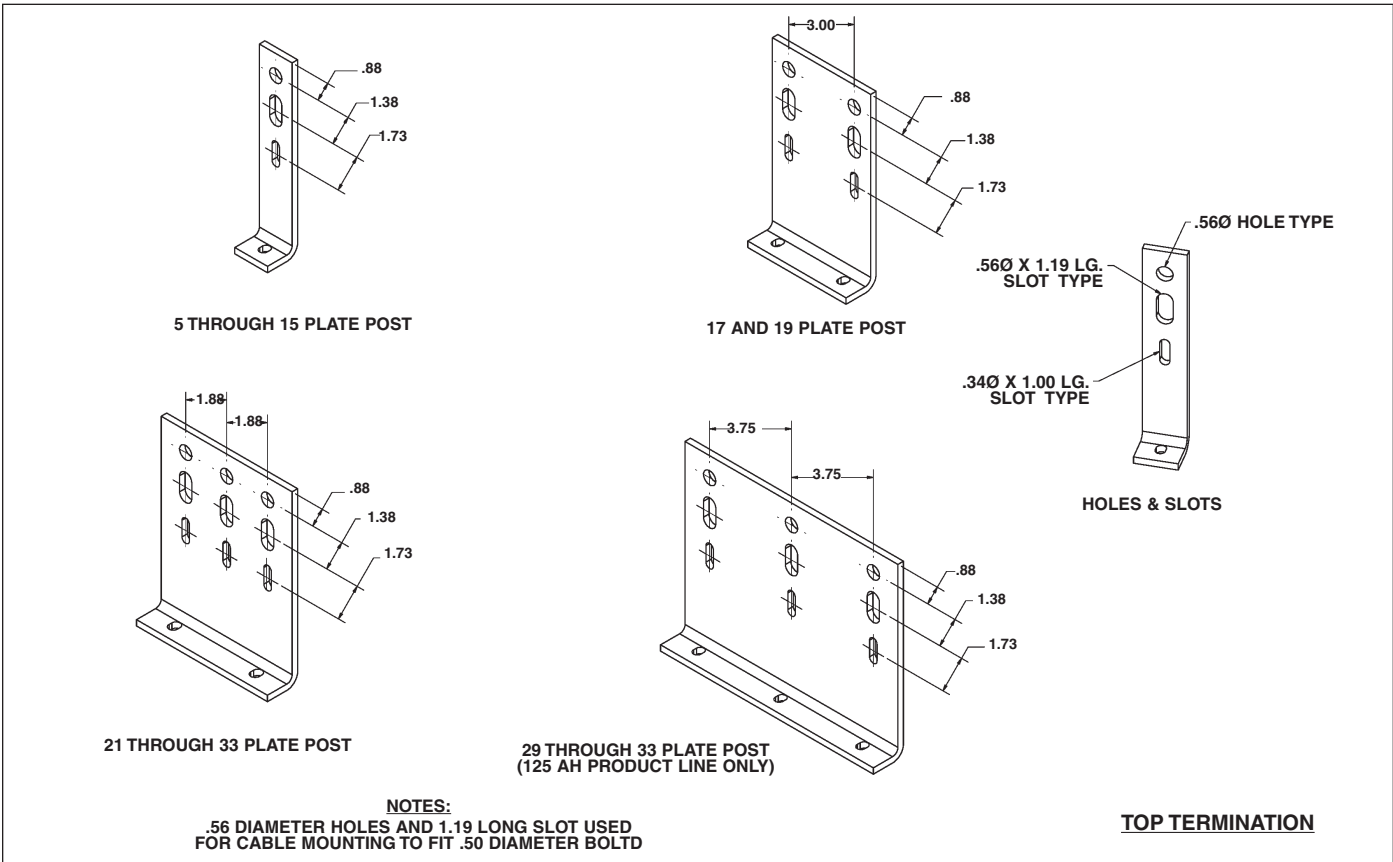

Fig. 7-1

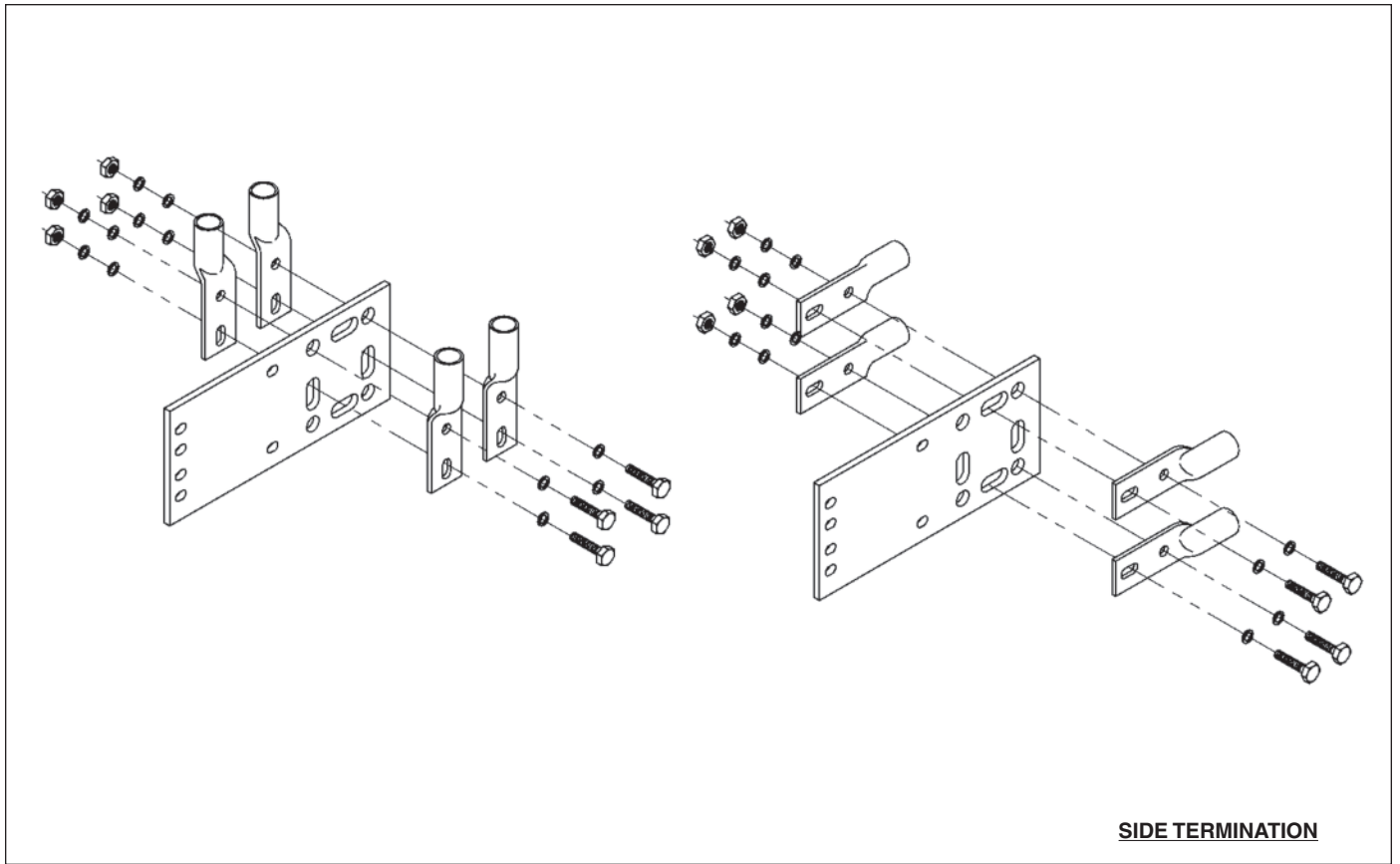
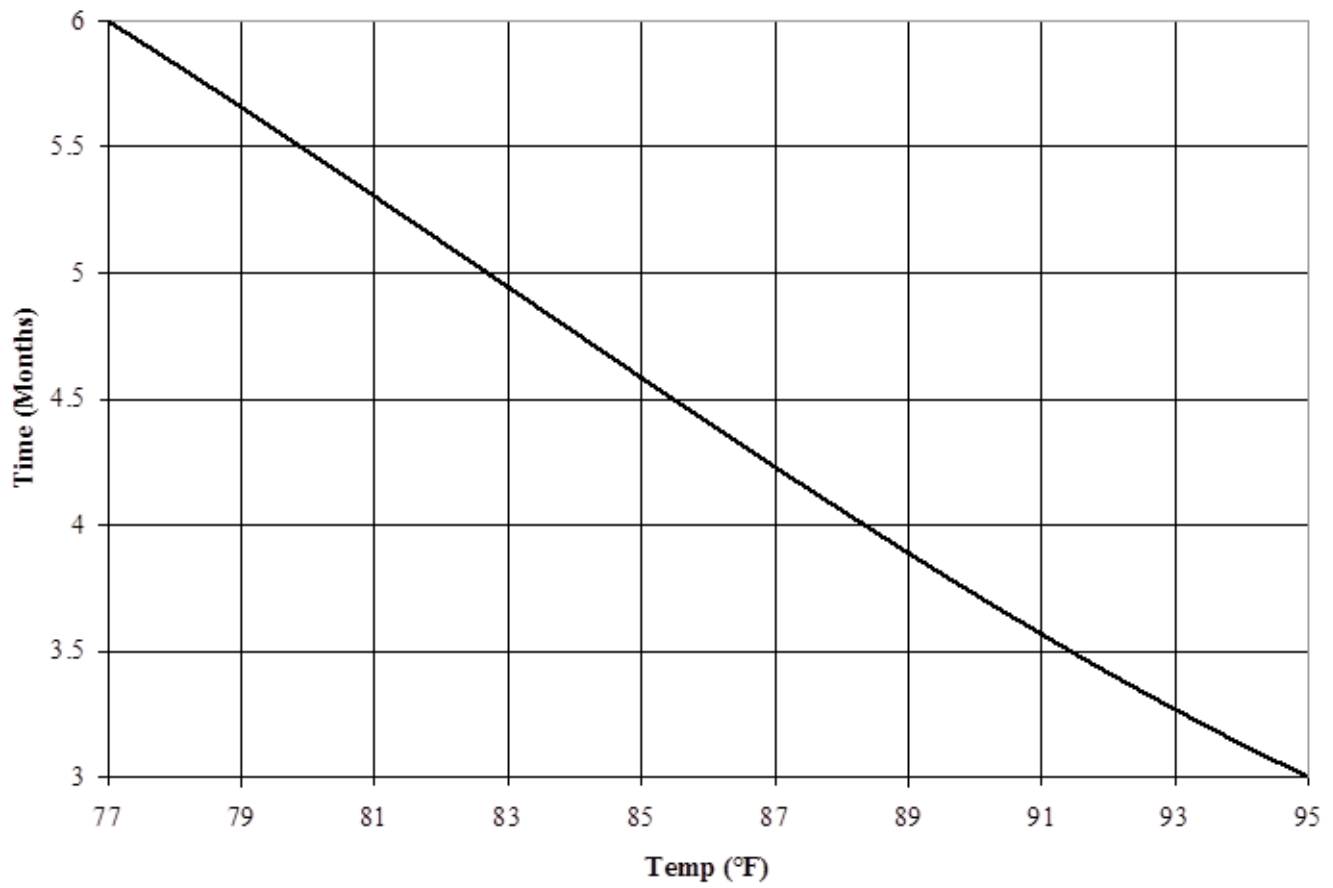

Fig. 7-1A

APPENDIX A

Recharge Interval Chart



APPENDIX B

Voltage Compensation Chart

°C	Float Voltage Per Cell	°F
≥35	2.230	≥95
34	2.232	93.2
33	2.234	91.4
32	2.236	89.6
31	2.238	87.8
30	2.240	86.0
29	2.242	84.2
28	2.244	82.4
27	2.246	80.6
26	2.248	78.8
25	2.250	77.0
24	2.252	75.2
23	2.254	73.4
22	2.256	71.6
21	2.258	69.8
20	2.260	68.0
19	2.262	66.2
18	2.264	64.4
17	2.266	62.6
16	2.268	60.8
15	2.270	59.0
14	2.272	57.2
13	2.274	55.4
12	2.276	53.6
11	2.278	51.8
≤10	2.280	≤50

2mV per °C

APPENDIX C

BATTERY MAINTENANCE REPORT

Date _____

Company _____

Address _____

Battery Location and/or Number _____

No. of Cells _____ Type _____ Date Mfg. _____ Date Installed _____

Charger Output _____ Ambient Air Temperature _____ °F

Total Battery Voltage _____ Panel Meter Volts _____ Installer _____

INDIVIDUAL CELL READINGS

Cell No.	Serial No.	Volts	Cell Ohmic Value	Connector Ohmic Value	Cell No.	Serial No.	Volts	Cell Ohmic Value	Connector Ohmic Value	Cell No.	Serial No.	Volts	Cell Ohmic Value	Connector Ohmic Value
1					21					41				
2					22					42				
3					23					43				
4					24					44				
5					25					45				
6					26					46				
7					27					47				
8					28					48				
9					29					49				
10					30					50				
11					31					51				
12					32					52				
13					33					53				
14					34					54				
15					35					55				
16					36					56				
17					37					57				
18					38					58				
19					39					59				
20					40					60				

Remarks and Recommendations _____

Readings Taken By _____

Readings should be taken at installation and at least annually thereafter.

Notation: This form must be completed and submitted with any product warranty claim.

APPENDIX D

Unigy II SPACESAVER® System Acid Volumes & Weights

Cell Size	Acid Wt gm	Acid Vol cc	Acid Vol gal	Acid Wt lbs	Pure Acid lbs
45-5	1,814	1,395	0.37	4.00	1.60
45-7	2,542	1,955	0.52	5.60	2.24
45-9	3,276	2,520	0.67	7.22	2.89
45-11	4,004	3,080	0.81	8.83	3.53
45-13	4,732	3,640	0.96	10.43	4.17
45-15	5,460	4,200	1.11	12.04	4.81
75-5	2,984	2,295	0.61	6.58	2.63
75-7	4,258	3,275	0.86	9.39	3.75
75-9	5,480	4,215	1.11	12.08	4.83
75-11	6,695	5,150	1.36	14.76	5.90
75-13	7,911	6,085	1.61	17.44	6.97
75-15	9,133	7,025	1.86	20.13	8.05
75-17	10,348	7,960	2.10	22.81	9.12
75-19	11,375	8,750	2.31	25.08	10.02
75-21	12,786	9,835	2.60	28.19	11.27
75-23	14,001	10,770	2.84	30.87	12.34
75-25	15,223	11,710	3.09	33.56	13.42
75-27	16,436	12,643	3.34	36.23	14.48
75-29	17,654	13,580	3.59	38.92	15.56
75-31	18,870	14,515	3.83	41.60	16.63
75-33	20,092	15,455	4.08	44.29	17.71
95-7	4,780	3,635	0.96	10.54	4.41
95-9	6,080	4,624	1.22	13.40	5.60
95-11	7,440	5,658	1.49	16.40	6.86
95-13	8,780	6,677	1.76	19.36	8.09
95-15	10,170	7,734	2.04	22.42	9.38
95-17	11,467	8,720	2.30	25.28	10.57
95-19	12,330	9,376	2.48	27.18	11.37
95-21	14,380	10,935	2.89	31.70	13.26
95-23	15,350	11,673	3.08	33.84	14.15
95-25	16,889	12,843	3.39	37.23	15.57
95-27	18,360	13,962	3.69	40.48	16.93
95-29	19,580	14,890	3.93	43.17	18.05
95-31	20,990	15,962	4.22	46.28	19.35
95-33	22,410	17,042	4.50	49.41	20.66
125-33	33,531	25,793	6.81	73.92	30.90
125LG-33	33,531	26,681	6.81	58.82	20.23

* Data subject to change.

NOTES

NOTES



www.dekabatteries.com

East Penn Manufacturing Co. Lyon Station, PA 19536-0147 Phone: 610-682-3263 Fax: 610-682-4781 e-mail: reservepowersales@dekabatteries.com